



**BIOLOGICAL OPERATING
MICROSCOPES**

МБР-1 and МБР-1А



Leningrad
Optical-Mechanical
Enterprises,
Amalgamated

**BIOLOGICAL OPERATING
MICROSCOPES**

МБР-1 AND МБР-1А

**TECHNICAL DESCRIPTION AND OPERATION
INSTRUCTIONS**

CONTENTS

I. Application	3
II. Specifications	4
III. Optical Diagram	6
IV. Design	8
V. Instructions for Use	14
1. Microscope Adjustment when Working with Artificial Light	14
2. Microscope Adjustment when Working with Natural Light	25
VI. Maintenance Instructions	26
VII. List of Spare Parts	28

I. APPLICATION

The type МБР-1 and МБР-1А biological microscopes are designed for investigation of transparent objects in transmitted light in the light field. They are used in medical, biological, bacteriological and other laboratories.

The type МБР-1 and МБР-1А microscopes are similar in construction and differ only by their outfit.

The microscopes design permits to use them for photographic purpose employing micro-photo-attachment МФН-7, МФН-8, МФН-9, МФН-12, to use a binocular attachment АУ-12, dark field condenser ОИ-13, phase-contrast device КФ-4 and other accessories (they are not included in the microscope set). Microscope normally operates in the premises with temperature from +10° to +45° and relative humidity not over 80 per cent. Operating of immersion objectives is ensured in the premises with temperature from +15° to +25° with the same humidity.

II. SPECIFICATIONS

Magnification:

MBP-1 microscope 56—1350×
 MBP-1A microscope 63—1350×
 Condenser aperture 0.3—1.2

Objectives

Objective	Magnification, X	Numerical aperture	Focal length, mm	Free distance, mm	Field of view of microscope with 10× eyepiece, mm	Maximum resolving power with direct lighting, μm
8×0.20	8	0.20	18.2	8.53	1.75	1.83
9×0.20	9	0.20	15.5	13.13	1.55	1.83
40×0.65	40	0.65	4.3	0.40	0.35	0.51
40×0.75 (water immersion)	40	0.75	4.3	1.64	0.35	0.48
90×1.25 (oil immersion)	90	1.25	1.9	0.10	0.15	0.28

Notes: 1. The magnification and aperture of each objective are engraved on mounts.
 2. The objectives are designed for 160 mm draw tube length and 0.17 mm thickness of cover glass.
 3. The objectives 8×0.20; 40×0.65 and 90×1.25 are applied to the MBP-1 microscope; whereas the objectives 9×0.20; 40×0.65; 40×0.75 and 90×1.25 are supplied with the MBP-1A microscope.

Eyepieces and total magnification of microscope

Eyepiece	Eyepiece magnification, X	Focal length, mm	Linear field of view, mm	Total magnification of microscope with objectives, X			
				8	9	40	90
Huyghens 7×	7	36	18	56	63	280	630
» 10×	10	25	14	80	90	400	900
» 15×	15	17	8	120	—	600	1350
Compensating 15×	15	16.7	11	—	135	600	1350

Notes: 1. The magnification of each eyepiece is engraved on the mounts.
 2. The Huyghens eyepieces, 7, 10, 15× are applied to the MBP-1 microscope. The Huyghens eyepieces 7 and 10× and compensating eyepiece 15× are applied to the MBP-1A microscope.

The fine focusing gear:

scale division value of reading drum 0.002 mm
 maximum backlash 0.002 mm

Object stage:

rotation angle 360°
 movement range 0—8 mm

Range of draw tube vertical movement 0—50 mm

Overall dimensions : 285×210×140 mm

Weight:	
МБР-1 microscope	3.35 kg
МБР-1А microscope	3.45 kg

III. OPTICAL DIAGRAM

Optical diagram of the microscope is divided into two systems: illumination system comprising a mirror 1 (Fig. 1), condenser 2 with iris aperture diaphragm 3 and movable filter 4, and observation system comprising objective 5, prism 6 and eyepiece 7, all incorporated in the microscope draw tube.

A beam of rays from either a natural or an artificial source of light falls on the mirror 1, reflecting the light and directing it to the aperture diaphragm 3. Then the beam passes through the condenser 2, the object under study, and further goes to the objective 5. The image of the aperture diaphragm is produced in the exit pupil of the objective thus achieving the most uniform illumination of the microscope field of view. The objective forms the image of the object under study onto the plane of field diaphragm of the eyepiece 7 used to observe the magnified image of the object.

The prism 6 declines the beam at an angle

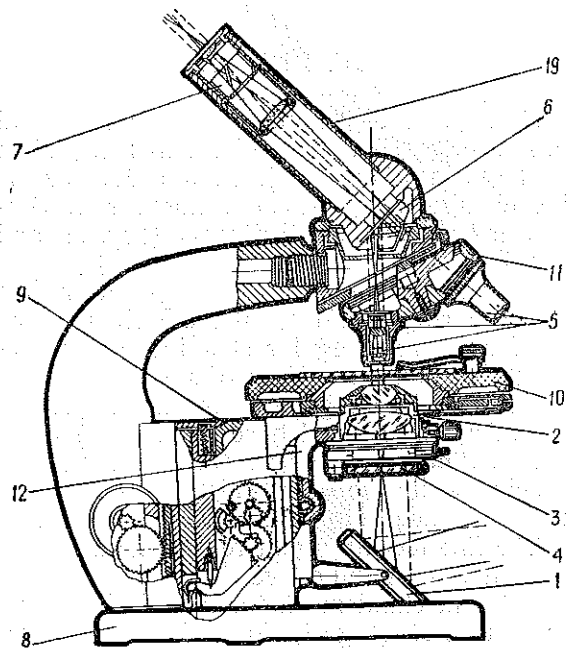

Fig. 1

of 45° from the vertical line. Inclined position of the outgoing beam of light secures convenience at operation with the microscope.

IV. DESIGN

Main parts of the microscope are: a stand base shoe 8 (Fig. 2), fine focusing mechanism enclosed in a box 9, object stage 10, revolving changer 11 on slides, condenser 2, condenser bracket 12, objective 5 (Fig. 1) and eyepiece 7.

Microscope base, of a horseshoe form, has three bearing platforms at the bottom, which platforms providing for steadiness of microscope base on the surface of stage.

The fine focusing gear box is screwed to the microscope stand base shoe. One side of the box bears a guide for the condenser bracket while the other side has a recess to move a guide with the draw tube holder.

The fine focusing gear represents a system of gear wheels and a lever.

This mechanism is actuated by turning knobs 13 (Fig. 2), located on the right and left sides of the box. Fastened on the right end of the knobs 13 axle is a drum with a scale provided with 50 divisions. Each fifth division is marked with figures beginning

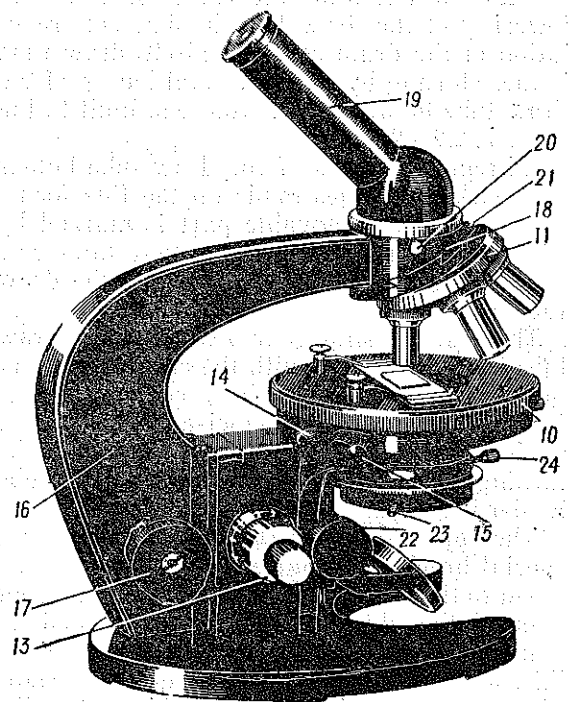

Fig. 2

from "0" to "9". Reading the drum scale it is possible to determine the value of rise and lowering of the draw tube holder. One revolution of the drum corresponds to draw tube holder shifting by 0.1 mm. Total length of the draw tube holder travel from one limit to the other is 2.2—2.4 mm.

Extreme positions of the draw tube holder are marked by lines made on the fine focusing gear box. A movable part is marked by a line and stationary one by two lines corresponding to extreme positions of the draw tube holder.

The fine focusing gear box shifts the draw tube holder together with the coarse focusing gear. By turning the knobs of coarse and fine focusing adjustment clockwise the draw tube holder of the microscope is lowered, while turning them counter-clockwise the draw tube holder is raised.

The object stage 10 (Fig. 2) is fixed on a special bracket; the latter, in its turn, is fastened to the fine focusing gear box. The upper disk of the object stage can be turned by hand holding it by its knurled part. To do this, loosen the screw 14. Besides, by means of two screws 15 (on the right side and on the left side) and a spring in the front part of the stage the latter can be moved for centering, thus enabling the observer to bring the

preparation of interest into the field of view.

On the stage surface there are seven holes: four extreme holes are designed for accommodation of spring clamps, three middle holes — for fixing a specimen driver which is not included in the microscope set.

The draw tube holder 16 in its lower part bears a guide and a gear with two knobs 17 intended for coarse focusing of the microscope. By turning knobs in opposite directions coarse focusing adjustment can be controlled.

In the upper part the draw tube holder bears a head 18 with a wedge guide, designed for the revolving changer and has a seat for setting an inclined monocular attachment 19. On the microscope can also be mounted either a direct or a binocular draw tube, which are not included in the set. The shape of the draw tube holder allows to place large-sized specimens on the object stage.

The inclined monocular attachment 19 is inserted into the socket of the draw tube holder head and is fixed in it by a screw 20. The attachment can be turned vertically to any position required.

The revolving changer 11 has four holes threaded for screwing in the objectives. Centered position of the objectives is secured

by a stop (detent) located inside the changer. The holes for the objectives on the changer are centered in respect of the draw tube axis with such accuracy that displacement of the point of the preparation in the centre of the view field of the eyepiece $7\times$ doesn't exceed two thirds of the field of vision radius when changing from an objective to any other one available in the present microscope complete set.

In the upper part of the revolving there is a guide of a dove tail type designed for mounting the changer onto the head of the draw tube holder. Correct position of the changer in respect of the draw tube axis is fixed by a screw 21 fastened by a locknut. The locknut and the screw are by no means allowed to be loosened, otherwise correct centering of the changer would be unsettled.

Bracket 12 (Fig. 1) of the condenser is fixed on the guide of the fine focusing gear box and can be shifted by turning the knob 22 (Fig. 2).

The bracket has a cylindrical sleeve for the condenser (Fig. 1). The condenser 2 is mounted inside the sleeve by means of a screw which is provided on the side of the bracket ring. The axle of the bracket gear on its left side bears a nut with two holes. Turning this

nut with a wrench, it is possible to adjust the bracket travel to that to achieve smoothness of the bracket travel and to prevent the bracket from sliding down. This adjustment is of particular importance while using a condenser with a phase-contrast device $K\Phi-4$.

The microscope condenser of two-lens type is equipped with an iris diaphragm, which can be opened and shut with the aid of a knob 23 (Fig. 2). While dealing with small magnifications, for instance, with the objective 8 or $9\times$, the upper front lens of the condenser can be removed (turned off), the condenser aperture being reduced from 1.2 to 0.3.

Rise of the bracket with the condenser is limited by the stop so that in its extreme position a clearance of 0.03 up to 0.2 mm is left between the plane of the object stage and the front lens of the condenser.

When using the immersion oil between the condenser front lens and the object glass the condenser aperture is 1.2, while without immersion oil the aperture equals 1.

The lower part of the condenser mounting is provided with a hinged frame for fixing a day-light filter or ground glass.

The microscope mirror has two reflecting surfaces: flat and concave. The concave

mirror is mainly used when operating without a condenser but with low-power objective.

V. INSTRUCTIONS FOR USE

Quality of image in microscope considerably depends upon illumination, therefore adjustment of illumination is an important preliminary operation.

To illuminate the preparation either artificial or natural light can be used. At precise work it is recommended to use artificial light. For artificial illumination a special illuminator OИ-19 is applied. While dealing with objectives of dry system of weak and average magnification one may use simplified removable illuminator OИ-31, which is installed in the microscope stand (instead of the mirror) by means of the dowel. The illuminator OИ-31 lamp is connected directly to the alternating current mains of 220 V. Illuminators OИ-19 and OИ-31 are not included in the microscope set.

1. Microscope Adjustment when Working with Artificial Light

Connect with a plank the illuminator OИ-19 and the microscope, in order to obtain normal illuminator-to-microscope distance.

Put microscope stand on two pins at one end of the plank and place illuminator on its other end. Plank pins should enter the slot at the bottom of microscope base, and illuminator pin should go into the plank slot.

The illuminator OИ-19 lamp is connected to the mains through a step-down transformer. The transformer is delivered connected to 220 V. To switch it over to 127 V one should adjust a switch through an opening located in the transformer bottom, and set it to number "127".

Note. On a special order the transformers can be also delivered with other input voltage to suit customer's requirements. In this case the voltage switch is set on voltage corresponding to that of customer's mains.

To control incandescence of the lamp provision is made in the transformer body for a rheostat with a handle, and to switch on the current a switch is provided.

After connecting the illuminator lamp to the transformer and the transformer to the mains it is possible to start adjustment of illumination.

First raise the condenser up to the stop by turning the knob 22 and shut the iris diaphragm of the illuminator, which is a field diaphragm of the microscope, up to its limit. The microscope mirror is to be turned by its

flat surface to the illuminator and to be adjusted approximately at an angle of 45° from the condenser axis.

Turning the illuminator in respect of the vertical and horizontal axes, direct a beam of light to the centre of the mirror. Turning the knob 23 shut the iris diaphragm of the condenser, which is an aperture diaphragm of the microscope. Shifting the lamp socket along the axis, achieve the most sharp image of the filament on the blades of the condenser closed iris diaphragm. The image of the lamp filament on the diaphragm should be seen clearly when looking at the microscope mirror from the illuminator side.

Take the objectives required for the work and insert them into the revolving changer. Arrange the objectives so that each next piece be more powerful than the previous one proceeding in clockwise direction if looking at the microscope from above when it is in its working position.

Operation with objectives 8×0.20 or 9×0.20 . The objectives 8×0.20 and 9×0.20 have the largest field of view and are mainly used as a view finder for preliminary examination of the preparation and choice of section for more detailed investigation.

If the objective 8×0.20 or 9×0.20 is supposed to be used within a long period of time

for work requiring low-power magnification (for instance, when investigating plankton) or when photographing, then it is recommended to remove a condenser upper lens from the illumination system. For this purpose, it is necessary to release a stop screw 24, take the condenser out of the bracket sleeve and screw off the upper front lens. Then put the condenser into the sleeve again and fasten with a screw. With the front lens being removed the image of the field diaphragm of the illuminator overlaps the entire field of view of the microscope.

If the objective 8×0.20 or 9×0.20 is used as a view finder, the condenser upper lens should not be removed because without the latter it is not possible to use more powerful objectives.

Further adjustment of illumination is to be effected as follows.

Place the preparation to the central part of the microscope object stage and press it by clamps. Place the objective 8×0.20 or 9×0.20 into the beam path. Set the eyepiece $7\times$ into the microscope draw tube. Open the field and aperture diaphragms. Turning the knobs 17 adjust the microscope for the preparation. Close the field and aperture diaphragms. Looking into the microscope, lower the condenser slowly down till the image of the

illuminator field diaphragm appears in the field of view. By swinging the mirror *1* (Fig. 1) bring the image of the field diaphragm into the centre of the field of view and open it entirely. If the condenser front lens is not removed, the image of the field diaphragm will be smaller than the microscope field of view. Therefore it is necessary to lower the condenser to such a position which gives way to full illumination of the entire field of view or place a ground glass in the hinged frame. After this, start studying the preparation.

Each of the objectives included in the microscope set can be employed with any of the eyepieces. However, at the beginning of examination it is recommended to use the low-power-eyepiece $7\times$.

Using the objective 8×0.20 or 9×0.20 , it is more convenient to move the preparation on the surface of the object stage directly by hand. There are two centering screws *15* (Fig. 2) for the accurate placing of the preparation on the object stage.

As it was indicated above, the upper disk of the stage can be rotated through 360° . The stage can be fixed in any position by a stop screw *14*.

Operation with objective 40×0.65 . Having chosen a section of the preparation proposed

to be studied in detail, place it in the centre of the field of view by means of centering screws of the object stage. If this operation is performed not very carefully, the section which is of interest to the observer could appear outside the field of view of a high-power objective.

Then turn the revolving changer and place the objective 40×0.65 in the path of beams. Further, adjust the microscope focusing for sharpness of the preparation image. As all objectives are intercoordinated, in order to adjust focusing, it is enough to turn slightly the knob *13* of the fine focusing adjustment gear. Having lifted the condenser up to stop, shut the illuminator field diaphragm; looking through the eyepiece bring the image of the field diaphragm to the centre of the microscope field of view by slightly tilting the mirror *1* (Fig. 1). Open the field diaphragm to such an extent that the diameter of its image becomes equal of that of microscope field of view. Find the most favourable opening size of the aperture diaphragm *3*.

The image of the aperture diaphragm is produced in the exit pupil of the microscope objective (near the last lens of the objective). This image could be seen when taking the eyepiece out of the microscope draw tube and

looking through the draw tube at the last lens of the objective. First the aperture diaphragm is to be completely closed. Then, looking at the exit pupil of the objective, gradually open the aperture diaphragm till the image of the diaphragm totally covers the opening of the exit pupil.

It is usually recommended to find such a size of the aperture diaphragm that the diameter of its image equals $\frac{2}{3}$ of the diameter of the microscope objective exit pupil. However, the final choice of the opening extent of the aperture diaphragm depends upon the nature of the preparation. The diaphragm should be opened so that the preparation image appears the most contrast. The aperture diaphragm being too widely open, the contrast of the image usually fades.

Never adjust the microscope for brightness of the image by narrowing the aperture diaphragm or by lowering the condenser, as this will reduce resolving power of the microscope.

To decrease brightness of the image either a day-light filter is placed into a hinged frame under the condenser or the lamp incandescence is reduced by means of the transformer rheostat.

Objective 40×0.65 produces a contrast and sharp image only when using cover glasses

0.17 mm thick. Image contrast considerably fades when thickness of cover glasses deviates from the indicated thickness by ± 0.02 mm. Thickness of cover glasses is measured with a screw micrometer.

Operation with objective 40×0.75 . If the water immersion objective is to be used for studying the preparation, then after a section of the preparation of interest has been chosen and brought in the center of the field of view by means of the objective 9×0.20 , the objective 40×0.75 should be introduced in the path of rays. After this the microscope focusing should be corrected and the chosen section of the preparation should be brought in the center of the field of view again.

When using the objective of water immersion, one should bear in mind that the objective is very sensitive for changing the cover glass thickness since the refraction index of water differs from that of the cover glass. The best quality of image while operating with this objective is obtained using the cover glass of 0.17 mm thick.

Prior to work apply a drop of distilled water onto the front lens of the objective 40×0.75 and the preparation.

While working with the objective 40×0.75 , the condenser is to be raised up to the stop.

It is not allowed to admit contact of the objective and the preparation as it can result in their damage.

The microscope is adjusted as follows.

At the beginning of focusing when the image of the object has not yet been seen in the field of view, it is recommended to shut almost completely the aperture diaphragm of the condenser, so that to increase depth of field of the microscope.

It is also advisable to control the centre position of the lamp filament image on the condenser aperture diaphragm plane (as it is indicated above). Looking from the side of the microscope stand at a gap between the objective and the preparation, turn the knob of coarse focusing adjustment and lower the draw tube holder very carefully almost till the contact of the objective with the preparation. In this case a layer of liquid appears between the front lens of the objective and the preparation.

Then looking through the eyepiece turn the fine focusing knob and raise the microscope draw tube holder until the sharp image of the object appears in the field of view. After this adjust centering and sharpness of image of the illuminator field diaphragm according to instructions stated for the objective 40×0.65 .

Take out the eyepiece of the microscope and looking through the microscope draw tube at the exit pupil of the objective, adjust the opening of the condenser aperture diaphragm.

After work, wipe off the distilled water from the objective and preparation with a clean napkin or wooden stick or match wrapped in cotton wool.

Operation with objective 90×1.25 . Before starting work with the immersion objective 90×1.25 , employ the objective 40×0.65 and eyepiece $7\times$, introduce as accurate as possible a section of preparation which is of interest for the observer in the centre of the field of view with the aid of centering screws of the object stage.

Prior to work apply a drop of immersion oil onto the front lens of the objective 90×1.25 and the preparation using a glass stick.

It is not allowed to use substitutes for immersion oil, because the application of substitutes would reduce contrast of image. After work wipe off immersion oil from the objective and preparation with the help of a clean napkin or wooden stick or match wrapped in cotton wool slightly wetted in alcohol or xylene.

While working with the objective 90×1.25 , the condenser should be raised up to the stop.

The indications given for the objective 40×0.75 concerning the microscope focusing, illumination adjustment and the extent of opening the diaphragms should be carried out for operation with the immersion objective 90×1.25 .

As in most cases the aperture of the illumination system does not exceed $\frac{2}{3}$ of the immersion objective aperture, there is usually no need to deliver immersion liquid between the front lens of the condenser and the preparation glass. In special cases when it is necessary to extend the illumination system aperture to the full aperture of the immersion objective some drops either of immersion oil or water are to be delivered to the front lens of condenser. The condenser is to be lifted to the stop. The preparation glass should be in contact with the liquid delivered on the condenser. The aperture diaphragm of the condenser is to be entirely open.

After work clean the condenser from oil in the same way as it is indicated above for the immersion objective.

2. Microscope Adjustment when Working with Natural Light

When working with natural (daylight) illumination, place the microscope so that the mirror would face the window. The mirror should direct light into the microscope either from a bright area of the sky or which is better from a light cloud.

Avoid such a position of the microscope when it meets direct sun beams forming too bright illumination which dazzles the observer.

Bright lateral light also interferes with observation especially when employing high-power eyepieces.

The day-light filter located under the condenser reduces brightness of the image and therefore should be removed at natural illumination.

At natural illumination there is no field diaphragm. Therefore the above stated instructions as to adjustment and the extent of opening the field diaphragm are not effective. All other instructions for placing the mirror, the condenser and opening the aperture diaphragm reserve their importance. By tilting the mirror achieve bright and uniform illumination of the field of view.

Foreign screening bodies (for instance, sashes) should not appear in the path of

beams as they would be seen in the exit pupil of the objective with the eyepiece taken out.

The microscope mirror is to face light by its plane side. Its concave side is applied very rarely only at work with low-power objectives.

When using objectives 40×0.65 , 40×0.75 and 90×1.25 lift the condenser to the stop.

VI. MAINTENANCE INSTRUCTIONS

The microscope is delivered carefully checked; to ensure trouble-free long-term operation the microscope should be kept clean and protected from damages. Packing ensures safety of the microscope during transportation. On receiving the microscope special attention should be paid to the seal which is to be intact.

Under the draw tube holder there is mounted a safety wooden block for disengagement of the fine focusing gear. To adjust the microscope to its working position, take this block from under the tube holder. If the revolving changer *11* displaces along the guides when delivering the microscope, move the changer until the screw *21* will rest against the draw tube head *18*.

When not in use, the microscope MBP-1 should be covered with a hood, and the microscope MBP-1A kept in a packing case. To preserve the appearance of the microscope, thoroughly remove dust and regularly wipe the microscope with a soft cloth wetted in acidless vaseline and then make it dry with a soft clean cloth.

Metal parts of the microscope should be always kept clean, but its optical components, objectives in particular, require a special care.

To protect the draw tube prism from dust, always keep the eyepiece in the draw tube or cover the latter with a cap.

Never touch the surface of lens with fingers. Should the objective last lens deeply seated in its mounting be covered with dust, wipe very carefully the lens surface with a clean cotton piece wrapped on a wooden rod and soaked slightly in pure benzine or ether.

If dust penetrates inside the objective, and if a deposit appears on the lens inner surfaces, the objective is to be sent for cleaning to a special workshop.

Don't take the objective apart yourselves to avoid their damage.

VII. LIST OF SPARE PARTS

Item No.	Name	Part or Assembly No.
1	Revolving changer plug	IO-27.47.123
2	Mirror in mount	IO-28.44.705 Cn
3	Wrench-screwdriver	IO-17.61.725 Cn
4	Attachment cap	IO-26.15.769
5	Achromatic objective 8×0.20 (M-42)	IO-41.11.002 Cn
6	Achromatic objective 40×0.65 (M11)	IO-41.11.004 Cn
7	Achromatic objective 40×0.75 (OM-23)	IO-41.11.203 BK
8	Achromatic objective 90×1.25 (OM-41)	IO-41.11.201 BK
9	Planachromatic objective 9×0.20 (OM-2)	IO-41.11.302 BK
10	Huyghens eyepiece 7× (M-7)	IO-41.31.107 Cn
11	Huyghens eyepiece 10× (M-10)	IO-41.31.108 Cn
12	Huyghens eyepiece 15× (M-11)	IO-41.31.109 Cn
13	Compensating eyepiece 15× (AM-27)	IO-41.31.501 Cn
14	CC2 blue light filter	IO-24.91.102
15	Π3 frosted glass	IO-24.91.101
16	Inclined monocular draw tube	IO-28.13.720 Cn