

5e. PRINCIPAL WEIGHTS AND DIMENSIONS

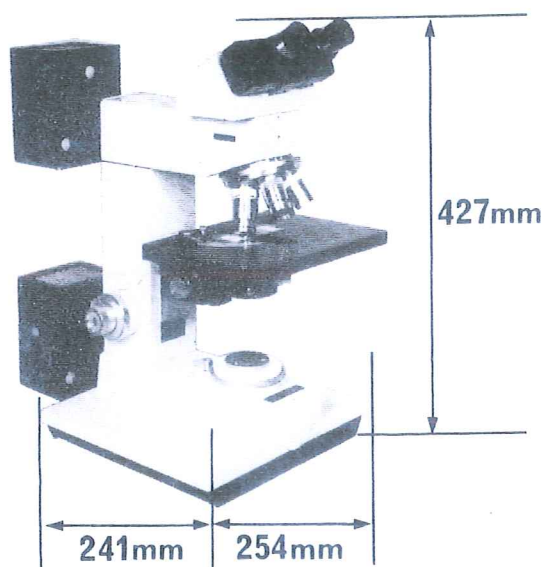

Approximate weight 11.8 kg (26 lbs.)

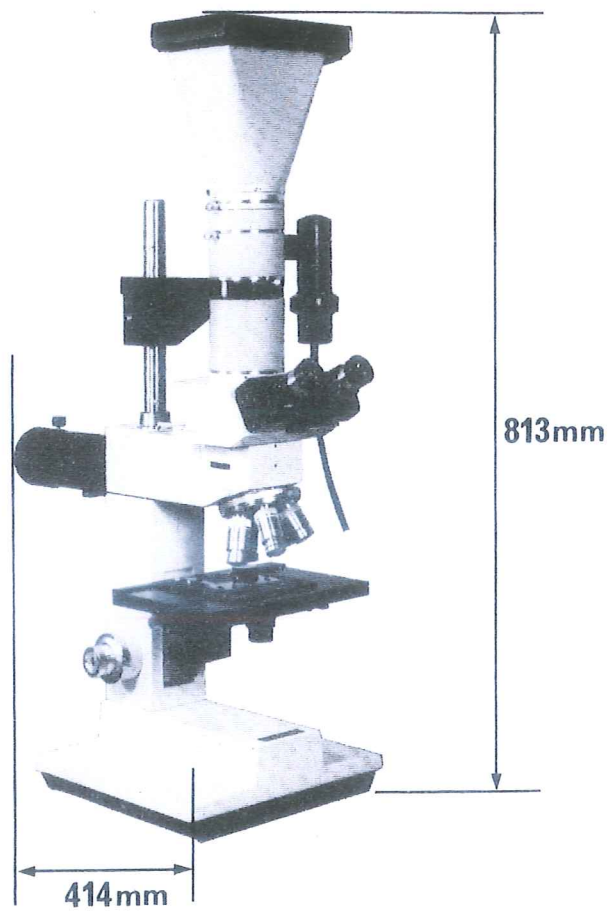

Approximate weight 13 kg (29 lbs.)

5f. LUBRICATION

Appropriate long-life lubricants are applied to all mechanical movements before leaving the factory; further attention should be required only after prolonged use.

Contact Vickers Instruments or their Agents if servicing is necessary.

6. PHOTOMICROGRAPHY

INTRODUCTION

Successful photomicrography does not demand an extensive knowledge of photographic theories and procedures. Results of consistently high quality are assured provided that:

(i) The microscope is correctly adjusted

The user should become thoroughly familiar with the operation and adjustment of the basic microscope before undertaking photomicrography since the film will faithfully record image defects which may not be obvious to the eye.

Focusing errors, uneven illumination and low contrast due to incorrect iris adjustment or dirty lenses are among the more common faults, all of which can be avoided if the microscope is carefully adjusted and the optics (including the specimen or slide) are clean.

(ii) A suitable type of film is employed

The ability of the microscope to resolve fine detail depends primarily on the Numerical Aperture of the objective; this resolving power *cannot* be enhanced photographically but can be degraded by use of an inappropriate film.

Specialist films with ultrafine grain and extremely high resolution are not generally necessary since the fine structure resolved by the objective is magnified before projection into the camera plane and is thus satisfactorily recorded by all but the coarsest (high-speed) emulsions.

Fine grain films (such as Kodak PANATOMIC-X or Ilford PAN-F, which give enhanced contrast) are quite satisfactory for all purposes other than those which demand a high degree of enlargement from a negative originally exposed at low power. (See further notes on empty magnification in Section 6e).

In general, the effect of emulsion grain in limiting ultimate resolution is less significant if a format larger than 35mm is employed.

Colour reversal film is particularly prone to reciprocity failure (tendency for the film to become less sensitive at low light levels, thus requiring abnormally long exposures) and demands close control over the colour temperature of the microscope illuminator. (See Section 6d: Colour).

In general, colour films which are balanced for artificial (tungsten) light are preferred, while those which are specifically designed for long exposures (such as Agfa 50L) have distinct practical advantages.

(iii) The film is correctly exposed

The required exposure depends principally on light intensity and emulsion sensitivity (film speed).

Light intensity: a simple averaged (wholefield) determination suffices for most purposes. The user must, however, be prepared to modify the shutter speed or meter setting to suit specimens in which a significant proportion of the field is markedly brighter or darker than the average.

Film speed: The speed of an emulsion cannot be defined by any single number. Manufacturers' published speed numbers (ASA or DIN) are based on a criterion of minimum useful exposure to an image of high contrast; microscopic images are generally of low contrast and record better if somewhat overexposed.

The required degree of overexposure will depend on image contrast and thus the effective film speed cannot be uniquely defined.

In the first instance therefore, trial exposures will be necessary to establish the response of the film under any given working conditions. (See Section 6c—Exposure).

6a BRIEF DESCRIPTION OF THE SYSTEM

Photographic equipment for M17 series microscopes includes both 35mm and large format cameras and has been specifically designed as an optional attachment system rigidly supported by the microscope stand. No complex projection optics are required, light being diverted to the camera tube (which accepts standard eyepieces) via a beam-splitting prism in the photovisual binocular head (20%-visual; 80%-camera) thus the image is fully visible during exposure.

The photovisual head has a compensating mechanism which moves the eyetubes in or out to maintain a constant 160mm tube-length as the interocular setting is altered. This ensures that visual and photographic images are always par-focal and allows the camera to be focused and framed via the binocular head with the aid of an eyepiece graticule.

The graticule is permanently mounted in either a 10x or 12.5x focusing eyepiece which carries an external scale; a corresponding scale on each camera body permits rotational alignment of camera and eyepiece when photographing elongated specimen features which may cross the field of view obliquely. To ensure parfocality the focusing eyepiece must always be used in the LEFT eyetube as the RIGHT tube carries the dioptic correction collar which effectively varies the tube length.

Eyepieces from 6.3x to 20x may be inserted in the vertical camera tube, giving a wide range of overall magnifications in the film plane (tabulated in Section 6e) but the possibility of empty magnification must be borne in mind when using the higher powers. Focusing 10x or 12.5x eyepieces may be used at this point if it is desired to project a graticule image into the film plane but careful adjustment is essential.

The framing graticule is marked as illustrated to indicate the photographic field corresponding to each camera eyepiece. The 35mm camera has a magnification factor of 0.4x and captures a field only slightly smaller than the larger format cameras, thus graticules for 35mm and large format are very similar; care must be taken to ensure that the correct eyepiece is used when precise framing is important.

N.B. Graticules are identified by the power of the viewing eyepiece and the camera format e.g. 10x 35mm; 12.5x 5 x 4 etc.

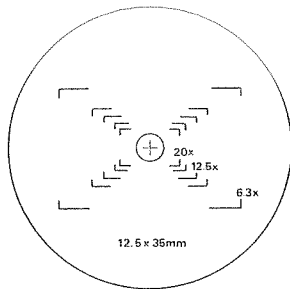

Framing graticule.

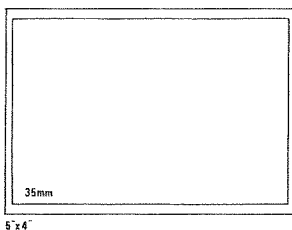

Relative photographic fields.

Proportion of visual image captured on film.

i.e. $\frac{(\text{Diagonal of photographic field})}{(\text{Diameter of full visual field})}$ expressed as %

Camera eyepiece	35mm format	Large format
6.3x	84%	95%
10x	53%	60%
12.5x	42%	48%
16x	33%	37%
20x	26%	30%

Exposures may be made manually using the speeded shutter and simple cadmium sulphide photometer, or automatically using the J35 electronic exposure unit coupled to an electromagnetic shutter. The beamsplitter tube diverts 20% of the available light to the photometer port and the J35 is calibrated accordingly; this factor should be borne in mind if some other form of photometer is to be employed.

Whole field photometry is completely adequate for most purposes but special circumstances involving localised highlights against an otherwise dark background may demand a "partial field" photometer which monitors only the light radiated by a small central area of the field. The central circle on the framing graticule describes the area monitored by the Vickers J37 partial field photometer, use of which is not described in this booklet as its application is somewhat specialised.

Magnification

The magnification in the film plane is the product of four factors:

- (i) Objective power: 2.5x to 100x. The actual magnification of any particular objective lies within a few percent of the nominal value engraved on the objective body.
- (ii) Microscope factor: This is 0.8x for the 25mm field microscope (type A); 1.0x for the 20mm field microscope (types B and C); 1.25x for the metallurgical and industrial microscopes (types D and E).
- (iii) Camera eyepiece power: 6.3x to 20x, engraved on each eyepiece body.
- (iv) Camera factor: This is 0.4x for 35mm cameras; 1.0x for Polaroid CB101 body; 1.25x for the 12.7 x 10.2cm (5" x 4") body.

Magnification factors inherent in any accessory systems fitted must also be taken into account.

The table in Section 6e gives available magnifications corresponding to the various combinations of objective, eyepiece and camera body; the numerical values have been rounded off, but are correct within a few percent.

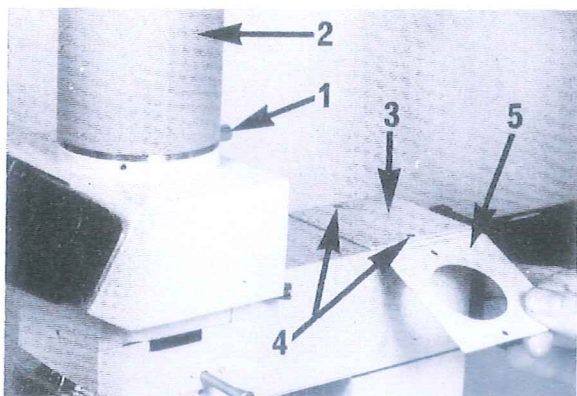

6b CAMERA SYSTEM – ASSEMBLY & LOADING

Assembly

Slacken clamp screw (1), remove the cover cap (if fitted) and clamp the vertical eyepiece tube (2) in position. Remove the blanking plate (3) by releasing the two small screws (4) and replace with the drilled plate (5) supplied with the camera equipment.

Insert the appropriate camera eyepiece (see Magnification chart, Section 6e).

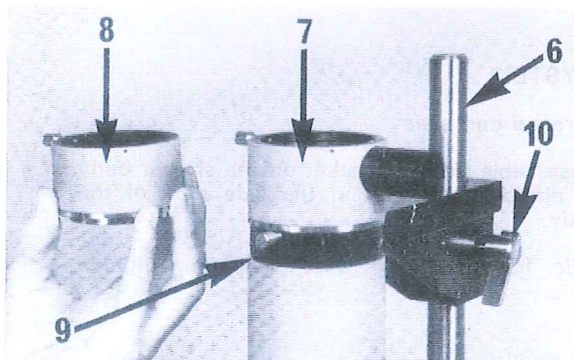

Screw the camera pillar (6) firmly into position and fit the beamsplitter tube (7) to the camera cross-arm; plain spacer tube (8) MUST be fitted if the beamsplitter is not specified.

Lower the cross-arm until male and female portions of the light trap (9) are engaged and lock in position (10).

The body length of the 16x or 20x eyepieces prevents the light trap engaging to its full depth. When these eyepieces are used the cross-arm should be lowered gently into contact with the eyepiece body and then raised approximately 2 – 3mm (1/16 – 1/8") before clamping. The light trap remains fully effective at this position.

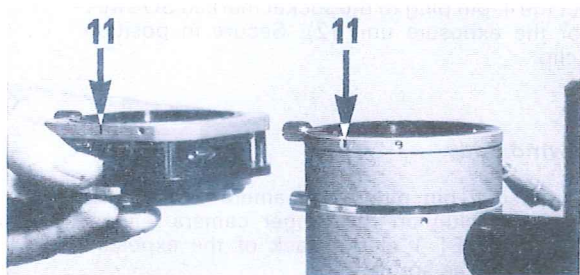

Fit the shutter (manual or electromagnetic) so that the engraved mark (11) on its upper flange will face the operator, and clamp in position.

Fit the camera so that division 5 of the engraved scale (12) is opposite the reference mark on the shutter body. NOTE THE POSITION of the DARK SLIDE where fitted.

Insert the focusing eyepiece with framing graticule in the LEFT eyetube and rotate it so that division 5 on the engraved scale is opposite the fixed mark on the eyetube.

NOTE: 35mm and CB101 (Polaroid pack film) cameras are fitted with a blind or dark slide above the mounting flange. When the camera is fitted so that the rotational scale is visible, THE DARK SLIDE POINTS AWAY FROM THE OPERATOR. The dark slide must not be overlooked; failure to remove it from the optical path renders photography impossible. The large format adaptor is not fitted with a dark slide since sheet films (including Polaroid Series 50 envelopes) are sealed in holders until exposure thus the camera body may be removed from the microscope without spoiling the film.



EXPOSURE SYSTEM

Manually operated cameras

Screw the release cable into the socket on the shutter body and insert the photocell housing in the side tube of the beamsplitter body.

See Section 6c for details of the cadmium sulphide photometer.

Electrically operated Cameras

Insert the photomultiplier in the side tube of the beamsplitter body and connect the 4-pin plug to the socket marked SOCKET 2 at the back of the exposure unit (2). Secure in position with the spring clip.

(i) 35mm Autowind body

Connect the shrouded 2-pin plugs on camera and shutter leads, insert the 8-pin plug on the longer camera lead in the socket marked SOCKET 1 at the back of the exposure unit (1) and secure with the spring clip.

(ii) Large format camera bodies

Connect the shrouded 2-pin plugs on the connecting cable and shutter lead and insert the 8-pin plug in the socket marked SOCKET 1 at the back of the exposure unit (1); secure with the spring clip.

Exposure unit—connection to mains (A.C. line)

Ensure that the mains (line) voltage selector (3) is set to the correct voltage and connect according to the detailed instructions on page 10 of this manual.

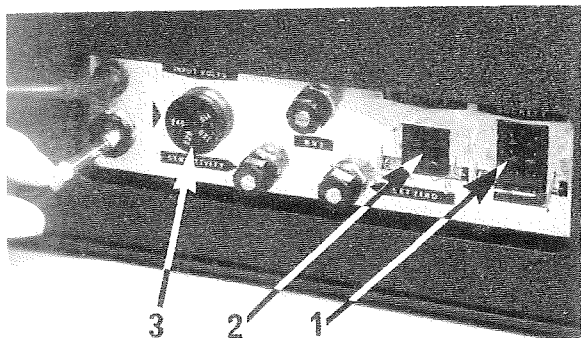

LOADING THE CAMERAS

35mm Manual and Autowind

Unlock and open the camera back by depressing the safety catch (4) and withdrawing the locking bar (5).

On the manual-wind camera the film rewind knob (6) must be depressed and rotated approximately 45° anticlockwise, which will cause it to spring out 6mm ($\frac{1}{4}$ ") from the casing.

Grip the rewind knob and pull it firmly, but carefully, out to its limit (a further 12–13mm or $\frac{1}{2}$ "). Place the cassette of film in the camera with the longer end of the spool away from the rewind knob. Push in the rewind knob, rotating it so that the forked spindle enters the film spool. Insert the cutaway film leader into the slotted take-up spool (7) so that the projecting pin engages a film perforation and turn the spool by its serrated edge to ensure that the film is firmly gripped and that the sprocket teeth project through the film perforations.

Take up any slack within the film cassette by rotating the rewind knob clockwise until a slight resistance is felt. The rewind knob of the manual camera should be depressed and given a further small clockwise rotation to lock it in position flush with the casing.

Close the camera back firmly and push the locking arm (5) in until the safety catch clicks into position.

Fit the camera to the microscope and turn the frame counter (8) anticlockwise so that the black diamond is opposite the pointer.

NOTE: There are two positions, for 36 and 20 exposure cassettes.

Before use, the film must be advanced three frames with the camera dark slide IN to clear the fogged leader.

The release button (9) on the manually operated camera must be depressed each time the film transport lever (10) is operated.

In order to operate the Autowind camera the J35 exposure unit must be switched ON and the photovisual head beamsplitter rod must be pulled OUT so that light reaches the photomultiplier tube. The "EXPOSE" button is pressed three times to advance the film, allowing sufficient time for the film transport motor to complete its cycle between operations. (See also Section 6c—Exposure).

Check that the film is advancing correctly by observing anticlockwise rotation of the rewind knob (6).

The frame counter should now indicate 36 or 20.

REMOVE THE DARK SLIDE prior to making an exposure.

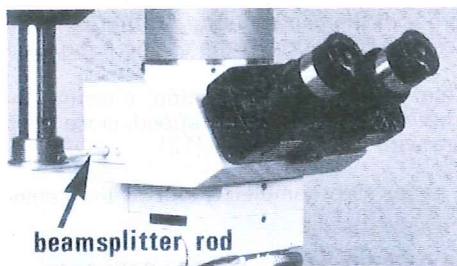
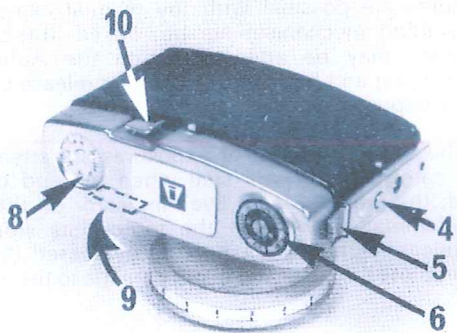
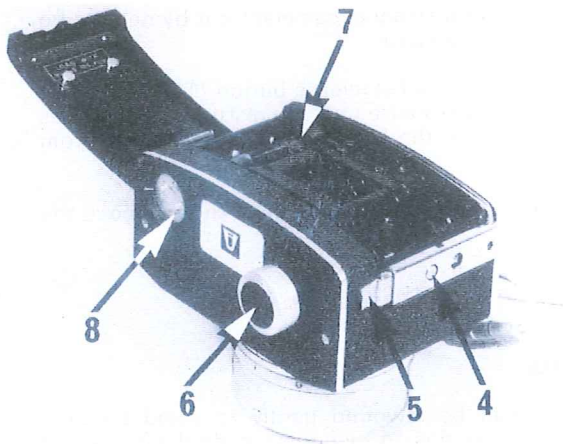

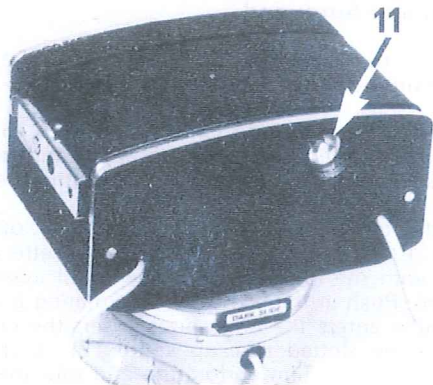

Removal of exposed film

When all frames have been exposed, rewind the film into the cassette as follows:—

Spring the rewind knob (manual cameras) out by depressing and turning 45° anticlockwise.

Depress and hold the sprocket release button (11) and gently turn the rewind knob clockwise until the resistance diminishes suddenly indicating that the film leader has disengaged from the take up spool.

Open the camera back, pull out the rewind knob, remove the exposed cassette.

General Points

Exposed film should be rewound gently to avoid possible scratching or marking due to electrostatic discharge. Avoid winding the film fully into the cassette; it will be easier to handle in the darkroom if the leader protrudes.

Double exposures are possible with the manual camera as shutter and winding mechanism are not linked. Intentional double exposures may be attempted with the Autowind camera by depressing and holding the sprocket release button (11) during the exposure cycle.

If more than the correct number of exposures are attempted the Autowind camera motor will stall when the end of the film is reached; the green "Magic Eye" indicator on the J35 unit will be illuminated although the motor has stopped. The sprocket release button (11) must be depressed IMMEDIATELY to complete the cycle and avoid damage to the motor.

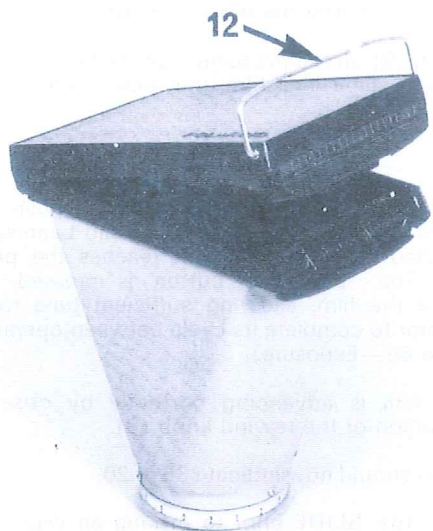

Polaroid CB101 (pack film) camera

Open the camera back by releasing the spring clip (12) and remove the empty film pack if the camera has been used previously.

Inspect the rollers for traces of dirt or developer jelly and clean if necessary with a moist lint-free cloth. The roller assembly may be sprung out of the camera body for thorough cleaning and to gain access to the inside of the casing if required.

Clip the new film pack firmly in position, ensuring that the white tabs are not folded under and trapped, close the camera back and secure with the spring clip (12).

Pull the black paper strip completely out of the camera and discard.

Remove the dark slide and make the exposure

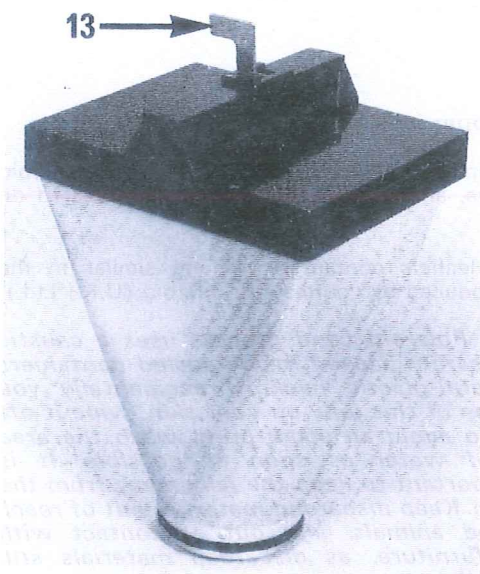

To process the print

Pull the white tab completely out of the camera, grip the yellow tab which appears and pull this *firmly* and *smoothly* until the picture is free from the camera. DEVELOPMENT COMMENCES AT THE MOMENT THAT THE YELLOW TAB IS PULLED, and timing according to manufacturers recommendation should start immediately.

Develop for the appropriate time and peel the print from the negative and mask, starting from the end nearer the yellow tab.

The developer jelly adhering to the negative is caustic, and may cause skin irritation. See safety note overleaf.

Large format camera body

The large format camera body accepts standard 12.7 x 10.2cm (5" x 4") plate or cut film holders or the Polaroid type 545 sheet film holder, which are locked in place by a spring mechanism actuated by a lever (13) on the camera body.

Cut film or plate holders must be loaded in the darkroom according to normal procedures which are not detailed in this booklet.

The Polaroid 545 Land film holder accepts Series 50 sheet films, each exposure being sealed in a separate light-proof envelope.

Follow the instructions on the envelope which is marked "This side toward lens" and "Do not press here"

Turn the lever (14) to 'L' and fully insert the film envelope until a click indicates that the metal tab is secured.

Withdraw the envelope until resistance is felt, and check that the negative and its developer pod have not been withdrawn with the envelope. If the developer pod can be felt at the position marked "Do not press here" the envelope should be reinserted and pushed firmly home to make sure that the metal tab is secured. Withdraw the envelope again, and make the exposure.

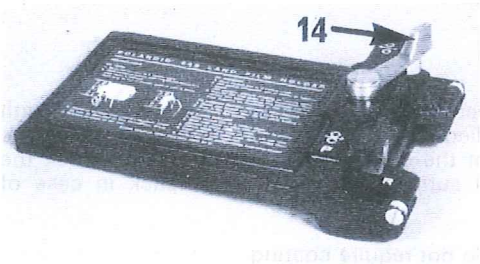

To process the print

Push the envelope fully in, turn the lever (14) to 'P' and pull the envelope *firmly* and *smoothly* from the film holder.

DEVELOPMENT COMMENCES AS SOON AS THE ENVELOPE IS PULLED THROUGH THE ROLLERS, and timing in accordance with the manufacturer's recommendation should start immediately.

When development is complete, tear open the envelope by gripping the end tabs, and separate the print from the negative and mask.

The developer jelly adhering to the negative is caustic and may cause skin irritation. See safety note below.

The design of the Polaroid 545 holder is such that the centre of the 11.4 x 8.9cm (4½" x 3½") picture area is approximately 3mm (⅓") from the true axis of the camera body; the centre of the picture area is displaced toward the *open* end of the film holder.

SAFETY NOTE

Polaroid developer jelly

Comprehensive instruction leaflets are supplied by Polaroid with each camera, and essential information is repeated on each film pack.

The instruction leaflets contain a warning similar to the following. (Reproduced by courtesy of Polaroid (U.K.) Ltd.):

CAUTION: The Polaroid Land process uses a caustic jelly which is safely packed inside sealed containers within the metal-plastic pack. If accidentally you should get some of this jelly on your skin, wipe it off immediately. To avoid an alkali burn, wash the area with plenty of water as soon as possible. It is particularly important to keep the jelly away from the eyes and mouth. Keep discarded materials out of reach of children and animals, and out of contact with clothing and furniture, as discarded materials still contain some jelly.

Print coating

Most Polaroid black and white prints must be coated with the lacquer supplied in the film pack in order to stabilise the image. This is not the case with Type 107C film; check the instruction leaflet supplied with each film pack in case of doubt.

Polacolor prints do not require coating.

6c EXPOSURE DETERMINATION

(i) Manual system, used without photometer

If no photometer is employed, results will be extremely unpredictable unless exposure conditions are meticulously recorded and standardised; trial exposures over a range of shutter speeds offer the only solution in the first instance.

Provided that the microscope is always operated at a pre-determined lamp voltage and that the specimen occupies most of the field of view, the mean light intensity in the film plane will be approximately constant for any given objective power, therefore the required shutter speed will be of the same order as that determined from the original trials.

The probability of success is improved by giving longer and shorter exposures in addition to the predetermined value. This procedure is described as "bracketing" and is strongly recommended; successive exposures should be made at HALF the indicated shutter speed, correct speed and DOUBLE the indicated speed. This will result in a series of frames which are one "stop" overexposed, nominally correct and one "stop" underexposed, from which the optimum result may be selected.

(In photographic terms, a change of one "stop" represents a factor of 2x, i.e. halving or doubling the shutter speed).

Most black and white films have sufficient latitude to tolerate rather larger exposure changes and thus a series of bracketed exposures from +2 stops (4x the "correct" exposure) to -2 stops ($\frac{1}{4}$ x the "correct" exposure) is permissible.

No detailed procedure can be laid down, but we would recommend that the standard exposure conditions should be recorded in the following manner:—

Date		
Nature of specimen: Microscope system: (Bright field, phase contrast etc.) Lamp setting: Diffuser IN/OUT Filters: Camera eyepiece:	Type of film:	
	Speed ASA/ DIN	
	Development: minutes in developer at °C	
	Objective power	Approximate shutter speed
	2.5x 4x 10x 20x 40x 100x	sec sec sec sec sec sec

**(ii) Manual system—
the cadmium sulphide photometer**

The simple cadmium sulphide (CdS) photometer consists of a battery driving a small electric current through a microammeter and a light-sensitive resistor.

The resistance of cadmium sulphide decreases at higher light intensities; the current therefore rises and the meter displays an increased deflection at higher levels of illumination. As the response of the circuit is non-linear the meter scale is not directly calibrated in terms of shutter speed; exposure times must be deduced from user-calibration charts which are completed on the basis of trial exposures under actual working conditions.

To prolong battery life, an OFF switch (1) is provided, which also gives an indication of battery condition. When the OFF button is *held* down the meter needle should deflect beyond the red dot on the scale; if it does not, the battery is nearing exhaustion and should be replaced.

To replace the battery, open the casing by removing the two screws in the base and observe the polarity of the battery in its mounting clip (-ve to chassis). Unclip the battery and substitute a new one (Ever Ready type B121 or equivalent: Vickers part number M030518) observing correct polarity and ensuring that the contacts are clean. Refit the casing, ensuring that the photometer lead is not kinked or pinched during reassembly.

X1/X10 range switches are provided (2) in order to accommodate a wide range of light intensities; very low readings and off-scale deflections cannot be interpreted accurately and should be avoided by use of filters or (for black and white film) varying the lamp output.

Calibration and use

Adjust the microscope to give a convenient level of illumination and note the photometer reading. Prepare a series of test negatives exposed at 1 "stop" intervals (e.g. $\frac{1}{2}$, 1, 2, 4, 8, 15 seconds shutter speed) without altering the lamp setting. Process these negatives under controlled standard conditions and select the one which is deemed most satisfactory. Enter the corresponding shutter speed in the appropriate column in one of the blank tables and fill in the remaining spaces as demonstrated by the following example.

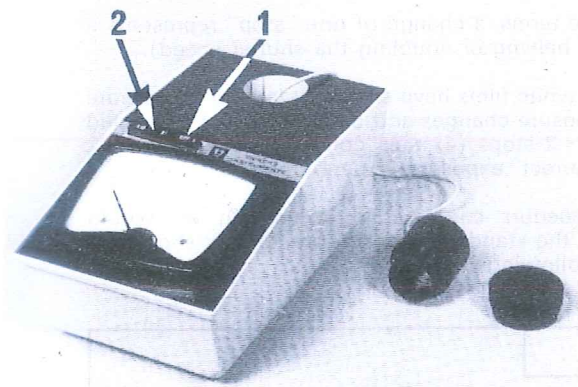

Example: With the photometer reading 1.0 on the x1 range, 2 seconds was found to be the optimum exposure for a particular type of film.

2 seconds is therefore entered in column 3 of the table. (Meter reading 0.6–1.2; x1).

As each column in the table covers a range of meter readings corresponding to 1 stop change in illumination and shutter speed the remaining spaces can immediately be filled in with the appropriate shutter speeds, as shown in the completed table below.

Meter Readings	x1 Range	0.1–0.3	0.3–0.6	0.6–1.2	1.2–2.5	2.5–5	5–10	—	—	—
	x10 Range	—	—	—	0.1–0.3	0.3–0.6	0.6–1.2	1.2–2.5	2.5–5	5–10
Shutter speeds (sec)		8	4	2	1	$\frac{1}{2}$	$\frac{1}{4}$	$\frac{1}{8}$	$\frac{1}{15}$	$\frac{1}{30}$

Slower ←—————|————→ Faster

If in subsequent use with a lower power objective or higher light intensity the photometer reads (say) 3.5 on the x10 range, the required exposure may be read directly from the table ($\frac{1}{15}$ second, Column 8).

Errors of plus or minus $\frac{1}{2}$ stop are possible if the actual meter reading is at or near the upper or lower limit in any given range but such a small error will not normally be noticed.

With a little mental arithmetic it is possible to use the results of one exposure trial to estimate shutter speeds for faster or slower films. We strongly recommend however that a separate table be compiled for each type of film *from the results of a practical test* since emulsion sensitivities vary significantly at low levels of illumination and manufacturers' published speed numbers may not be valid.

Manufacturers' data sheets may be consulted in an attempt to compensate for reciprocity failure (declining sensitivity at long exposure times) and other effects but a trial exposure provides the only direct practical test.

For a type of film which is particularly prone to reciprocity failure it may be necessary to fill each space in the exposure tables as the result of a separate test. This procedure is tedious and most users will find it more convenient to adjust the illumination (by means of filters etc.) to achieve a standard meter reading and shutter speed known to give satisfactory results. This approach is particularly suitable for colour film.

Some users may find it convenient to draw up an extended exposure table in the form of a wallchart tabulating meter readings and corresponding shutter speeds for all films used in their laboratory. Such a wallchart is *not* produced by Vickers Instruments; several blank tables are provided at the back of this booklet for your convenience.

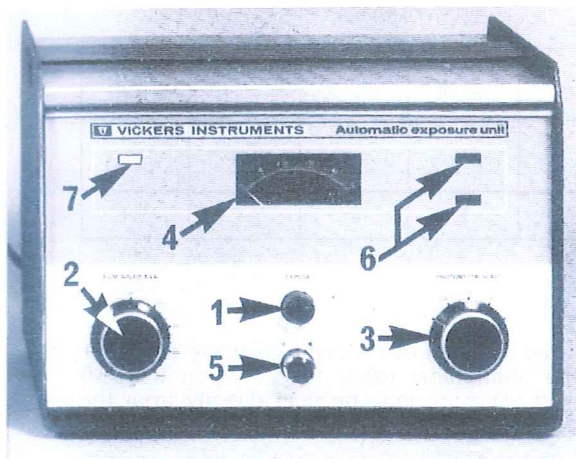

(iii) Automatic exposure system (J35)

The J35 electronic exposure unit controls a variable speed electromagnetic shutter (1/50 sec–15 mins.) and supplies the drive voltage for the Autowind 35mm camera; the shutter opens when the EXPOSE button (1) is pressed and closes when the voltage across a resistance-capacitance control network reaches a predetermined value. The time-constant of the R-C network is selected by a film-speed selector switch (2) graduated in $\frac{1}{3}$ -stop intervals from 5 to 3200 ASA, while the charging current is determined by the light intensity falling on a vacuum-tube photomultiplier (R.C.A. Type 931A or equivalent).

As the response of the photomultiplier tube is linear it is possible to expose automatically over a very wide range of light intensities without recalibration, hence a three position range switch (x100/x10/x1) is provided (3). This switch, which also has an OFF position and a T setting for manually-timed exposures, is normally turned to whichever position gives an on-scale reading on the microammeter (4); the actual meter reading is unimportant provided that it is above the red portion of the scale (on x1 range) in which region leakage currents could lead to non-linear overall response. The relationship between meter reading (μA), film speed (ASA) and exposure time (sec) is charted below for reference.

NOTES: The film-speed selector knob carries TWO index marks; setting the WHITE mark gives correct exposures for 35mm cameras (magnification factor 0.4x) while the BLUE mark gives 2 stops additional exposure to allow for the higher magnification (1.0x/1.25x) of the larger format camera bodies.

In photomicrography, most reversal films (colour transparencies) and all Polaroid types are generally found to require 3–4 stops longer exposure than black-and-white negative films of the same nominal speed. A two-way switch (5) changes the overall sensitivity of the J35 by 4 stops to suit these differing requirements; its setting is shown by the two red indicators (6) which also show that the unit is switched ON.

The position of this switch does NOT affect the relationship between meter reading, film speed and exposure time.

N.B. If a speed faster than 1/50 second is indicated (shaded area of chart) the shutter will not open fully and results will be unreliable.

Care must therefore be taken when working with high speed film at high levels of illumination.

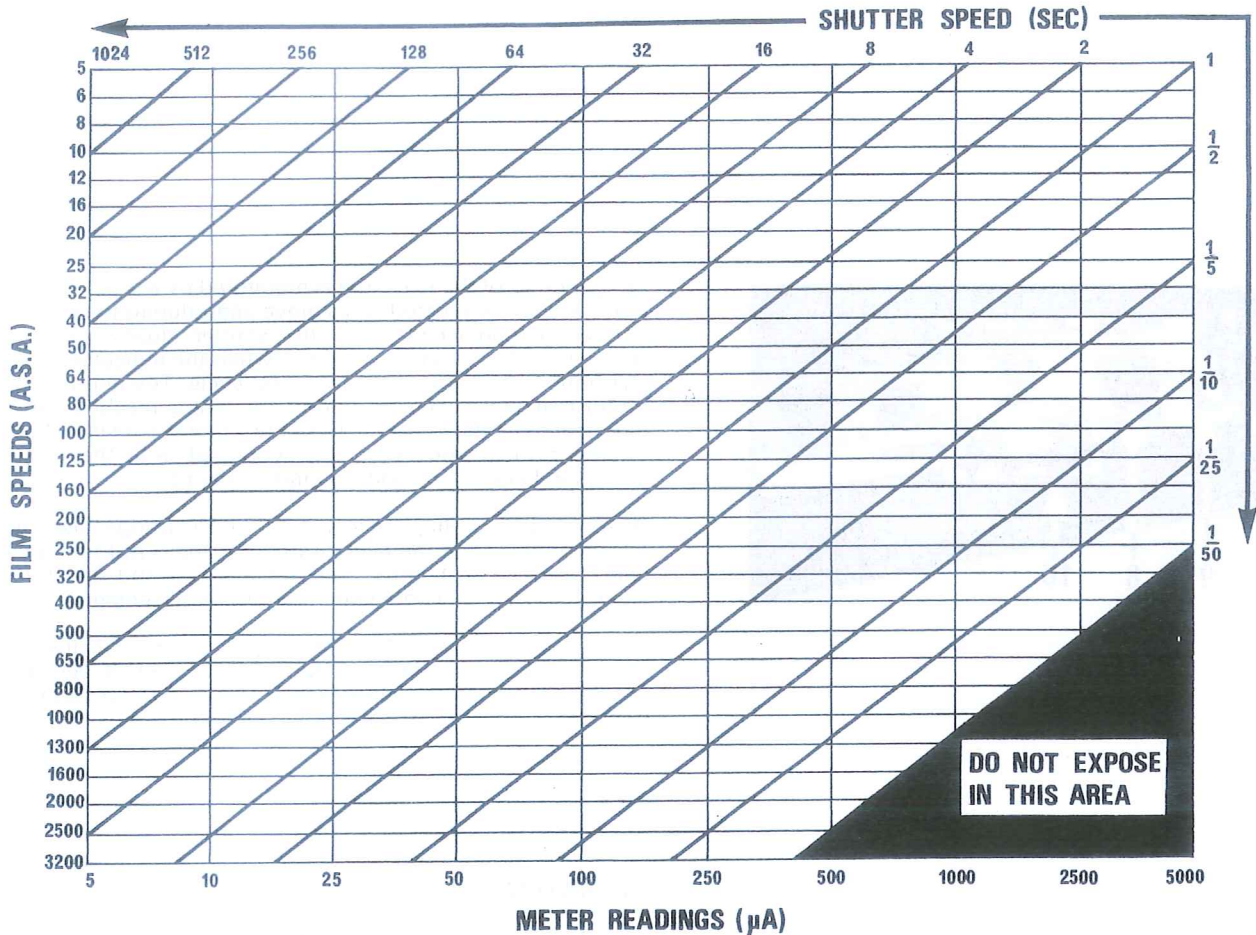

Microammeter readings, film speeds and shutter times for Vickers J35 set for 35mm film (using WHITE index mark).

Examples of Using the chart

- (a) *What will be the shutter speed for 100 ASA film exposed at a meter reading of 400 μ A (i.e. 40 on x10 range)?*

Locate the meter reading (400) on the lower axis, then trace vertically to meet the horizontal at 100 ASA.

The intersection lies between the $\frac{1}{2}$ sec. and 1 sec. diagonals; indicated speed is approximately 0.6 sec.

- (b) *What light intensity (meter reading) should be set in order to achieve 1 second exposure for 50 ASA film?*

Locate the 1 second diagonal and trace down to the intersection with the 50 ASA horizontal.

From the intersection trace vertically to determine the meter reading from the lower axis—in this case 500 μ A (i.e. 50 on x10 range).

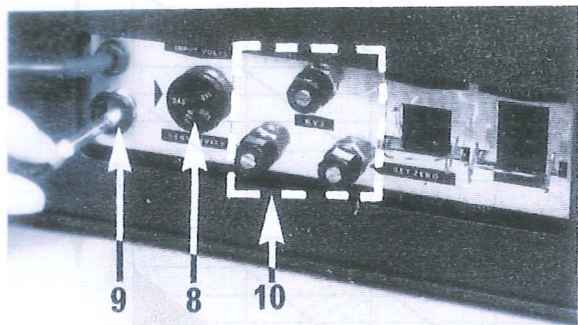

The progress of the exposure is monitored by a green indicator (7); the two illuminated areas move apart during the exposure and are extinguished when the shutter closes unless the Autowind 35mm camera is in use, when the indicator remains ON until completion of the wind-on cycle. The film transport motor may stall when the end of the film is reached and the indicator will then remain ON; the sprocket release button on the camera body must be depressed until the cycle is completed before manually rewinding the film.

A mains (line) voltage selector (8) and cartridge fuseholder (9) are mounted at the back of the unit adjacent to the mains lead (power cord) entry. See sections 1b and 5a (iii) for details of electrical connection and fuse replacement.

The preset controls (10) affect the overall sensitivity of the unit and must *not* be disturbed by untrained personnel. Contact Vickers Instruments or their agents if J35 performance is suspect.

OPERATION

Switch the unit ON by turning the range switch to x100 and allow 2–3 minutes to warm up.

If a black and white negative film is in use, turn the film type switch to NEGATIVE; for colour reversal (transparency) films and all Polaroid types the switch should be turned to REVERSAL.

Select the film speed using white or blue index mark as appropriate. The optimum film speed may not be that published by the manufacturer; see notes on "Trial Exposures".

Adjust the microscope according to normal procedures, pull the viewing head beamsplitter rod OUT and observe the J35 meter reading. If using colour film, adjust the lamp voltage and insert conversion filters to achieve the correct colour temperature (Section 6d) before proceeding further. Turn the range switch to x10 or x1 if the meter reading is low or reduce the illumination if the needle is off-scale. Reduction *must* be by insertion of neutral density filters for colour photography but for black and white film it is permissible to lower the lamp voltage.

When the meter displays a moderate deflection, make the exposure by depressing the EXPOSE button. REMEMBER TO PULL THE DARK SLIDE OUT (35mm and CB101 cameras).

If the needle does not deflect beyond the red zone on x1 range the exposure must be made manually. Turn the range switch to T and open the shutter by pressing the EXPOSE button. Press the EXPOSE button again after the required time to close the shutter.

Trial exposures using the J35

The manufacturer's film speed number is intended as a guide only; the actual response of any particular film under working conditions *must* be established by preliminary trial exposures at different settings of the ASA dial.

A graded test strip is easily produced on 35mm film by changing the speed setting between exposures; set a LOWER speed number to OVEREXPOSE and a HIGHER speed number to UNDEREXPOSE. The speed selector is graduated in $\frac{1}{3}$ -stop intervals, thus three "clicks" represents an increase or decrease of 1 stop.

Black and white films have considerable latitude and a series graded in intervals up to 2 stops is permissible; a logical sequence should be adopted for ease of interpretation e.g.:— if the nominal film speed is 100 ASA.

Frame number	1	2	3	4	5	6	7
Meter setting (ASA)	800	400	200	100	50	25	12
Effect	-3 stops			"correct"			+3 stops

Colour reversal films have limited latitude and the test strip should be finely graded in intervals of $\frac{1}{3}$ stop (1 "click") or $\frac{2}{3}$ stop (2 "clicks"). The 4-stop difference between negative and reversal ranges may be excessive for some colour films, particularly if the image is of higher than normal contrast. In this case the optimum meter setting may be considerably higher or lower than the nominal film speed; this is of no consequence in practice.

All normal precautions should be taken when exposing a test strip on colour film (see section 6d—colour). A procedure for making trial exposures on sheet film is described in section 6c (iv), below.

Once an effective film speed is established the J35 may simply be reset to this value each time the same film is used unless the image includes significant localised highlights or is of such low intensity that a further reciprocity correction is required.

Reciprocity correction from data sheets

To combat reciprocity failure when long exposures are unavoidable, the shutter speed obtained from the J35 calibration chart may be modified in accordance with film manufacturers' data sheets by turning the ASA dial to a new (lower) value.

Data sheets commonly recommend EITHER that the aperture of the camera lens be opened by a given number of stops (an adjustment which does not exist on the microscope) OR that the exposure be prolonged by a given factor.

As reciprocity failure is progressive at longer exposures, the recommended changes in shutter speed (at constant illumination) are usually *greater* than the corresponding aperture adjustments (at constant shutter speed).

Corrections can only be applied by resetting the J35 film speed dial to a lower value to prolong the exposure; care must thus be taken to ensure that the dial is reset in accordance with the *shutter speed* recommendations rather than those for the *lens aperture*.

Note also that modified processing conditions may be recommended for film given unduly long exposures.

GENERAL POINTS — ALL CAMERA SYSTEMS

Trial exposures on sheet film (using large-format camera body)

The cost of trial exposures on sheet film (including colour film and Polaroid) is considerably reduced if the blind or dark slide is used to mask parts of the film in order to build up a composite exposure graded in "stops" (i.e. a 1, 2, 4, 8, 16 sequence).

The simple fundamental rule is to make the first two exposures identical and to double the exposure at each subsequent step as the film is progressively masked by the blind.

The following example gives FIVE strips but more can be accommodated by moving the blind less than 25mm (1") between exposures.

Example: For a nominal exposure of $\frac{1}{4}$ sec, a test strip from -2 stops to +2 stops must be exposed at $\frac{1}{15}$, $\frac{1}{8}$, $\frac{1}{4}$, $\frac{1}{2}$ and 1 second.

Pull the blind or envelope out to uncover the whole film and give $\frac{1}{15}$ sec exposure. Return the blind in 25mm (1") steps, giving further exposures at $\frac{1}{15}$, $\frac{1}{8}$, $\frac{1}{4}$ and $\frac{1}{2}$ sec.

The equivalent exposures received by each strip of film are indicated schematically below:—

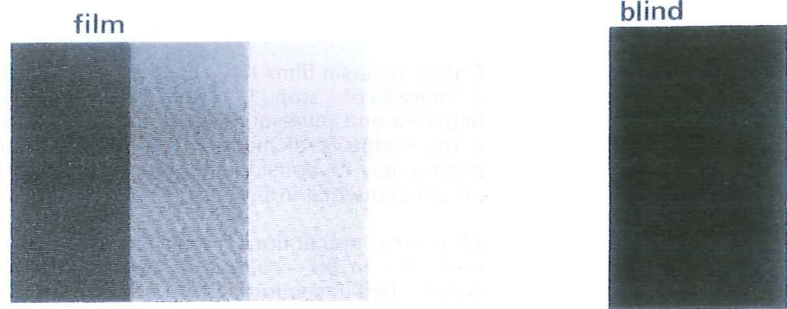

Exposure No.	Speed					
1	$\frac{1}{15}$	$\frac{1}{15}$	$\frac{1}{15}$	$\frac{1}{15}$	$\frac{1}{15}$	$\frac{1}{15}$
2	$\frac{1}{15}$	$\frac{1}{15}$	$\frac{1}{15}$	$\frac{1}{15}$	$\frac{1}{15}$	
3	$\frac{1}{8}$	$\frac{1}{8}$	$\frac{1}{8}$	$\frac{1}{8}$		
4	$\frac{1}{4}$	$\frac{1}{4}$	$\frac{1}{4}$			
5	$\frac{1}{2}$	$\frac{1}{2}$				
Total equivalent Exposure (sec.)		1	$\frac{1}{2}$	$\frac{1}{4}$	$\frac{1}{8}$	$\frac{1}{15}$
Relative exposures		16	8	4	2	1

A similar test series may be built up by varying the J35 film speed dial between exposures. If the theoretical film speed is 400 ASA, 2 stops underexposure is achieved by setting the dial to 1600 ASA. A double exposure at 1600 ASA is equivalent to a single exposure at 800 ASA, double at 800 ASA is equivalent to 400 ASA, etc.

Therefore a 5-step sequence exposed at 1600, 1600, 800, 400 and 200 ASA is equivalent to 5 separate exposures at 1600, 800, 400, 200 and 100 ASA, i.e. from 2 stops *under* to 2 stops *over* the nominal film speed.

Localised highlights

Both J35 and CdS photometers record an averaged (or un-weighted) value of the illumination over the whole field of view—a measurement which is sufficiently accurate for routine specimens in which bright and dark areas are uniformly distributed.

However, where bright areas predominate the mean illumination is high and the indicated shutter speed is correspondingly fast. There is thus a tendency towards *underexposure* when dealing with thin biological slides or un-etched metallic specimens.

Conversely, an image consisting of relatively few highlights against a dark ground will tend to be *overexposed* since the low overall illumination calls for a slow shutter speed. This situation may be met in polarized light or dark-ground microscopy.

These problems are overcome by use of the partial-field photometer (J37) in extreme cases, but in most normal circumstances it is sufficient to apply an approximate correction *reducing* the exposure where the image is *predominantly dark* and *increasing* the exposure where the image is *predominantly bright*.

An approximate "rule of thumb" may be stated as follows:—when photographing brightly illuminated features which occupy X% of the field of view, give X% of the indicated exposure.

The rule is *not* rigorous; it is intended as an easily-remembered guide for trial exposures. When recording *dark* areas (non-metallic inclusions or densely stained tissue) exposures must be *extended* proportionally, rather than reduced.

Focusing eyepiece to project graticule image into film plane

The microscope must be carefully adjusted to ensure that the projected image of the graticule is well defined.

Essential steps are:

- (1) Set the microscope up carefully using a low power objective (10X), taking particular care over adjustment of the binocular head and framing eyepiece (Section 2b).
- (2) Swing the camera cross-arm aside and insert the 10X or 12.5X focusing eyepiece (with appropriate graticule) in the vertical camera tube.
- (3) **Without** altering the microscope focusing controls observe the image in the vertical eyepiece and turn its focusing sleeve until graticule and specimen images are observed to be co-planar.

(Slight eye movements should produce no relative motion of graticule and specimen images).
- (4) Turn the whole eyepiece so that the graticule markings lie in a convenient direction relative to the specimen, swing the camera cross-arm back into position and proceed normally.

Essential pre-exposure checklist

- (1) FOCUSING. Each user must carefully adjust the framing eyepiece, binocular head and microscope focus according to the detailed instructions in Section 2b.
At low power it is often difficult to assess precise focus; adjustment is correct when slight eye movements cause no movement of the image relative to the framing graticule.
- (2) EVEN ILLUMINATION. Any defects may be emphasised by temporarily closing the APERTURE iris. Do not forget to reset the iris correctly before exposure.
- (3) IRIS SETTINGS. FIELD and APERTURE irises must be correctly set for best results. The "seven tenths" APERTURE setting should be the standard, but the iris may be opened a little for high contrast specimens.
- (4) DARK SLIDE and PHOTOVISUAL PRISM. Check for correct position.
- (5) SHUTTER SPEED. Check that the exposure unit is set for the correct film speed, type and format (J35) and that the meter is on-scale; OR that the manual shutter is set to the speed indicated by the CdS meter calibration table.

6d FILTERS IN PHOTOMICROGRAPHY

(i) Black and white photography

The appearance of the final print may be closely controlled by judicious use of coloured contrast filters to darken selected features of a multi-coloured specimen. Panchromatic films offer greatest flexibility since orthochromatic films do not respond to red light; red features therefore will *always* appear black or very dark in a print taken from orthochromatic films.

It is important to note that any filter transmits light of its own colour freely while partially absorbing light of the complementary colour. Since both J35 and CdS photometers monitor the image-forming light *after* filtration, they automatically compensate for the loss of intensity by indicating longer exposures; specimen areas of the *same* colour as the filter are thus *lightened* in the final print while areas of *complementary* colour are *darkened*.

Filter colour	Colour of specimen				
	Red	Orange	Yellow	Green	Blue
Red	●	▲	★	★	★
Orange	●	●	▲	★	★
Yellow	●	●	▲	▲	★
Green	★	★	▲	●	★
Blue	★	★	★	▲	●

● — Lighter
 ▲ — Unchanged
 ★ — Darker

} in final print

Any filter may be inserted in the illuminating path from lamp to specimen but only optically correct filters should be inserted in the image-forming path from specimen to viewing head.

The following are the more commonly used glass filters; other glass types may be supplied to special order.

Filter colour	Glass Manufacturers' code numbers		19mm ϕ for filter slide	32mm ϕ for substage trays	40mm ϕ for lamp filter housing (mounted)
	Chance	Schott			
Red	OR2	RG610	M173680	M151536	M173582
Orange	OY1	OG570	M173681	M151538	—
Yellow	OY4	OG515	M173682	M151539	—
Green	OGR1	BG9	M173683	M151535	M173584
Daylight blue	OB8	BG34	M173684	M151540	M173586
Deep Blue	OB10	BG12	M173685	M151527	M173604
Turquoise	OB2	BG23	M173686	M151545	—

Green Filter

The green filter is particularly important in black-and-white photomicrography since it transmits only the range of wavelengths for which the Microplan (achromat) objectives are spherically corrected. Residual aberrations in the red and blue-violet regions of the spectrum are suppressed and therefore overall image contrast is significantly enhanced.

The green filter should always be fitted when photographing uncoloured preparations on black and white film and is recommended for coloured preparations *provided that* its presence does not produce unwanted contrast effects between areas of different colour.

As the response of the photometer varies with wavelength, insertion of a colour filter may modify its overall sensitivity to some extent. Therefore exposure trials should be conducted with the filter in position for critical work.

(ii) Colour film

Filters are necessary in colour photography for three main purposes:

- (a) To convert the colour temperature of the illuminator.
- (b) To achieve a shutter speed within the operating range of the emulsion.
- (c) To correct colour imbalance due to reciprocity failure.

Several filters may be necessary to perform all three corrections simultaneously.

(a) Light source conversion

The quality of an illuminant (other than an arc source which emits a discontinuous spectrum) is most conveniently described by its 'colour temperature' which is closely related to the actual temperature of the radiating surface. High temperature sources such as the sun emit relatively more blue light than lower temperature sources such as the tungsten filament lamp, therefore colour reversal films designed for daylight exposure have lower blue-sensitivity than those intended for use in artificial light, in order to maintain correct colour balance.

The colour temperature of the 30W lamp is approximately 2900K at 6 volts while the 100W lamp is adjustable from 3100–3400K simply by setting the operating voltage in the range 10.5–12.7 V (see characteristics, below).

The 100W lamp is therefore adjustable to suit all artificial light films without filtration but requires a conversion filter for use with daylight film. The 30W lamp requires blue filtration for both daylight and artificial light colour films.

Only those filters which are specifically designed for light source conversion should be used for critical colour work; the 'daylight blue' filter supplied with the microscope gives an approximate conversion for visual purposes and is not intended to match the characteristics of any particular film.

The filters quoted in the following examples are from the Kodak 'Wratten' series of bluish light-balancing filters available from photo-dealers; they are not supplied by Vickers Instruments. The following should be regarded as a guide only; for critical work trial exposures should be conducted with each new batch of colour film.

6V, 30W lamp

Run lamp at 6 volts, check with voltmeter where possible. Use the following for initial exposure trials. Since colour temperature varies with age, bulbs should be changed frequently for critical colour work. Nominal colour temperature 2900 K at 6 volts.

Required balance	3100K	3200K	3400K	5500K
Filters	82A	82B	82 + 82C	80A + 82B

12V, 100W lamp

Whenever possible the lamp should be run at a voltage which gives the correct colour balance without filtration; however if the voltage exceeds 11.5 volts bulb life will be shortened and it may be preferred to use mild filtration to achieve temperatures above 3200 K.

Required balance	3100K	3200K	3400K	5500K
Lamp voltage/filters	10.5V/—	11.5V/—	12.7V/— or 10.5V/82B	10.5V/80A+82 or 11.5V/80A

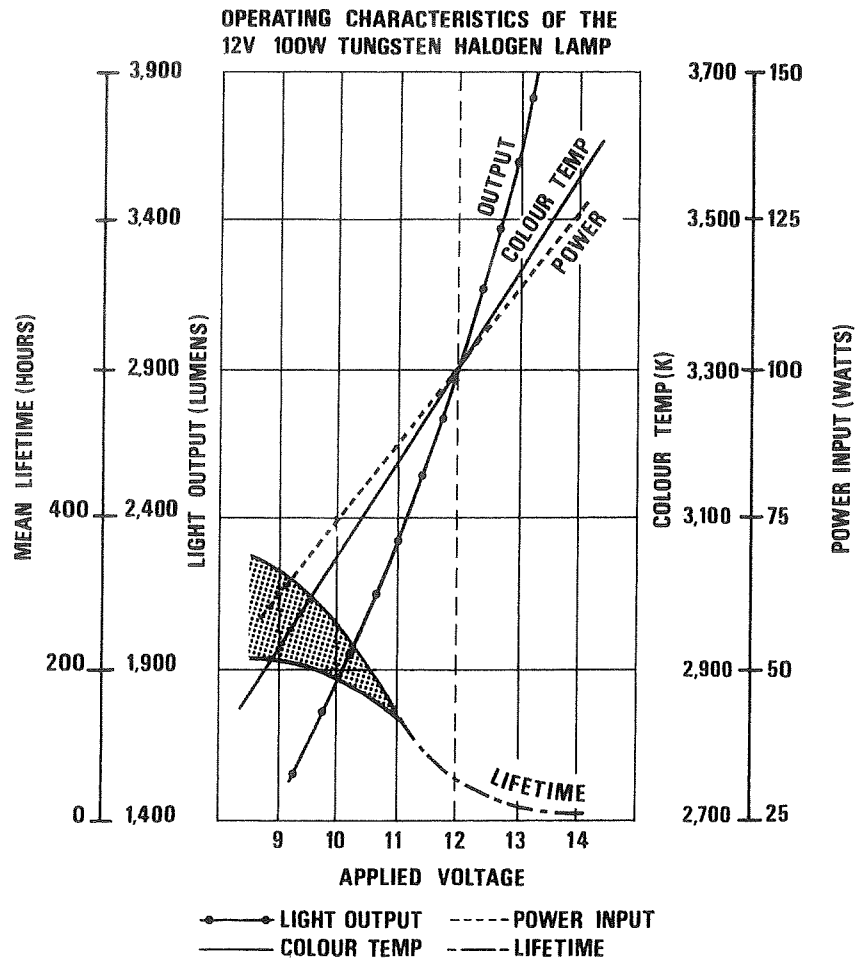

Light source conversion is less important when using colour negative film since additional filtration may be employed when printing from the negative. The use of light balancing filters is recommended however, since the additional dark-room work may be inconvenient, particularly when films are processed and printed by a commercial photo-finisher whose staff may be unfamiliar with the intended appearance of the photomicrograph.

A correctly exposed colour transparency can often serve as a guide to colour balance when prints are to be produced commercially.

(b) Shutter speed adjustment

All colour films are designed to give neutral colour balance over a specific range of light intensities and corresponding shutter speeds. It is common for the overall illumination in photomicrography to be so low that colour casts due to reciprocity failure are encountered, demanding the use of correction filters as described in paragraph (c), below.

However, it is equally possible that specimens of high reflectance or transmittance will demand short exposures when the illumination is turned up to a level giving the correct colour temperature. Such short exposures may be beyond the capability of the electromagnetic shutter or may be faster than those for which the film was designed, particularly if it is a type intended for longer-than-normal exposures.

It may thus be necessary to introduce neutral density filters in order to reduce overall illumination without introducing a colour shift.

Modern 'Inconel' metallised filters as supplied by Vickers Instruments are far superior to the older glass or gelatin filters which were not completely colour-free. The table gives Vickers' code numbers for available neutral density filters.

Note: The density of a filter is defined as follows:—

$$\text{Density} = \log_{10} \left(\frac{1}{\text{Transmission}} \right)$$

Thus a filter transmitting 50% of the incident illumination will have a transmission factor of 0.5 and an optical density of 0.3.

For most purposes, transmission values are more easily interpreted than densities, since they may be directly related to changes in shutter speed.

Density/Transmission	Vickers code numbers	
	19mm ϕ , for filter slides	40mm ϕ for lamp or substage filter holders
0.6/(25%)	M173670*	M173592
1.0/(10%)	M173670*	M173594
2.0/(1%)	M173670*	M173596

*Code M173670 includes three neutral density filters and slide.

When the quality of the illumination has been adjusted to the correct colour temperature, read the photometer and determine the indicated exposure. If the shutter speed is too fast for the film, simply insert one or other of the neutral density filters until the meter indicates a shutter speed within the operating range of the emulsion.

(c) Correction of colour shifts

Reciprocity failure does not affect all three layers of a colour emulsion to the same extent and therefore colour balance will be distorted at long exposure times. Moderate-speed artificial light films generally suffer relatively mild shifts which may be eliminated by inserting pale colour-compensating filters of the Kodak 'Wratten' CC series, while high-speed daylight films tend to suffer severe colour shifts which are difficult to correct.

CC filters are available from photo-dealers in the three primary colours Red, Green, Blue and their complementary colours Cyan, Magenta, Yellow, in densities from 0.05 to 0.5.

The required filter is always of a colour complementary to the dominant tint of the photograph, thus an overall bluish tint is corrected by a yellow filter while a yellowish tint is corrected by a blue filter, etc.

Film manufacturers' data sheets must be consulted in order to select CC filters for any given application since film characteristics are extremely variable. The recommendations at the end of this chapter, which cover a few typical films, should be regarded only as starting points for exposure trials.

6e MAGNIFICATION TABLES

It is most important to distinguish between useful and empty magnification, both for visual observations and for photomicrography.

The smallest interval resolved by the optical microscope is given by the familiar equation:

$$h = \frac{0.5 \times \lambda}{\text{N.A.}}$$

where h = smallest interval resolved
 λ = wavelength of illuminating beam
N.A. = numerical aperture of objective

If the overall magnification in the final image is less than a certain minimum value (approximately 250x N.A.) the finest detail resolved by the objective is still below the limit of resolution of the eye, assuming the microscope to be adjusted so that the final image is 25cm (10") from the eye.

Raising the overall magnification to approximately 500x N.A. reduces viewing strain but if the magnification of the final image exceeds 1000x N.A. the eye is fully able to resolve the finest detail revealed by the objective and further magnification serves no useful purpose.

The range from 500x N.A. to 1000x N.A. is commonly described as useful magnification while magnifications in excess of 1000x N.A. are described as empty.

It is normally assumed that the final print will be viewed at the standard distance of 25cm (10") from the eye therefore the same 1000x N.A. criterion may be applied to the overall magnification of the photomicrograph including any additional magnification due to enlargement or other copying processes. Photomicrographs reproduced at magnifications of 1000x N.A. and above always appear unsharp and lack definition; this cannot be avoided.

Typical print sizes and the corresponding minimum enlargements from the 35mm negative are:

$3\frac{1}{4}'' \times 4\frac{1}{4}''$ (8.2 x 10.7cm)	.	.	3x
$4'' \times 5''$ (10.2 x 12.7cm)	.	.	4x
$4\frac{3}{4}'' \times 6\frac{1}{2}''$ (12.0 x 16.5cm)	.	.	5x

Objective/eyepiece combinations which yield a print magnification in excess of 1000x N.A. when thus enlarged are indicated in the table for the 35mm camera.

In the tables for larger format cameras objective/eyepiece combinations which exceed 1000x N.A. at the film plane are indicated; if the sheet film negative is to be enlarged, the initial exposure should preferably be made at a lower magnification.

Where there are alternative objective/eyepiece combinations giving a particular magnification the higher objective power and lower power eyepiece are always preferred since the resulting negative will tolerate greater enlargement.

Note: The tabulated magnifications have been rounded off to the nearest DIN values, but are correct within a few percent. Where precise magnification is significant the user must calibrate the optical system by photographing a suitable scale (stage micrometer).

The DIN magnification series is based on a geometric progression with a common ratio of $\sqrt[3]{10}$, or 1.259. In round terms the basic series is as follows:

1.25 1.6 2.0 2.5 3.2 4.0 5.0 6.3 8.0 10.0

DIN-preferred overall magnifications are multiples of the base series and are tabulated in bold type. The ASTM series is similar, except that it includes 75x and 750x in place of 80x and 800x; 150x and 1500x in place of 160x and 1600x.

CAMERA MAGNIFICATIONS

M17 biological microscope—25mm field of view

Multiply the figures in these tables by any additional factors due to accessory systems. DIN-preferred magnifications are shown in bold type.

(a) with 35 mm camera (camera factor 0.4x)

Objective power (N.A.)	Camera eyepiece				
	6.3X	10X	12.5X	16X	20X
2.5X (0.08)	5	8	10	12.5	16
4X (0.12)	8	12.5	16	20	25
10X (0.25)	20	32	40	50	63
20X (0.50)	40	63	80	100	125
25X (0.50)	50	80	100	125	160
40X (0.65 or 0.75)	80	125	160	200	250
50X (0.95)	100	160	200	250	320
100X (1.25)	200	320	400	500	630

Exceeds 1000X N.A. if enlarged 3X

Exceeds 1000X N.A. if enlarged 4X

Exceeds 1000X N.A. if enlarged 5X

(b) with Polaroid CB101 camera (camera factor 1.0X)

Objective power N.A.	Camera eyepiece				
	6.3X	10X	12.5X	16X	20X
2.5X (0.08)	12.5	20	25	32	40
4X (0.12)	20	32	40	50	63
10X (0.25)	50	80	100	125	160
20X (0.50)	100	160	200	250	320
25X (0.50)	125	200	250	320	400
40X (0.65 or 0.75)	200	320	400	500	630
50X (0.95)	250	400	500	630	800
100X (1.25)	500	800	1000	1250	1600

≥1000 N.A.

(c) with 5" x 4" camera body (camera factor 1.25X)

Objective power N.A.	Camera eyepiece				
	6.3X	10X	12.5X	16X	20X
2.5X (0.08)	16	25	32	40	50
4X (0.12)	25	40	50	63	80
10X (0.25)	63	100	125	160	200
20X (0.50)	125	200	250	320	400
25X (0.50)	160	250	320	400	500
40X (0.65 or 0.75)	250	400	500	630	800
50X (0.95)	320	500	630	800	1000
100X (1.25)	630	1000	1250	1600	2000

≥1000 N.A.

CAMERA MAGNIFICATIONS

M17 biological microscope—20mm field of view

Multiply the figures in these tables by any additional factors due to accessory systems. DIN-preferred magnifications are shown in bold type.

(a) with 35mm camera (camera factor 0.4X)

Objective power (N.A.)	Camera eyepiece				
	6.3X	10X	12.5X	16X	20X
2.5X (0.08)	6.3	10	12.5	16	20
4X (0.12)	10	16	20	25	32
10X (0.25)	25	40	50	63	80
20X (0.50)	50	80	100	125	160
25X (0.50)	63	100	125	160	200
40X (0.65 or 0.75)	100	160	200	250	320
50X (0.95)	125	200	250	320	400
100X (1.25)	250	400	500	630	800

Exceeds 1000X N.A. if enlarged 3X

Exceeds 100X N.A. if enlarged 4X

Exceeds 1000X N.A. if enlarged 5X

(b) with Polaroid CB101 camera (camera factor 1.0X)

Objective power (N.A.)	Camera eyepiece				
	6.3X	10X	12.5X	16X	20X
2.5X (0.08)	16	25	32	40	50
4X (0.12)	25	40	50	63	80
10X (0.25)	63	100	125	160	200
20X (0.50)	125	200	250	320	400
25X (0.50)	160	250	320	400	500
40X (0.65 or 0.75)	250	400	500	630	800
50X (0.95)	320	500	630	800	1000
100X (1.25)	630	1000	1250	1600	2000

≥1000 N.A.

(c) with 5" x 4" camera body (camera factor 1.25X)

Objective power (N.A.)	Camera eyepiece				
	6.3X	10X	12.5X	16X	20X
2.5X (0.08)	20	32	40	50	63
4X (0.12)	32	50	63	80	100
10X (0.25)	80	125	160	200	250
20X (0.50)	160	250	320	400	500
25X (0.50)	200	320	400	500	630
40X (0.65 or 0.75)	320	500	630	800	1000
50X (0.95)	400	630	800	1000	1250
100X (1.25)	800	1250	1600	2000	2500

≥1000 N.A.

6f EXPOSURE RECOMMENDATIONS — COLOUR FILM

Trial exposures will be necessary when using any type of film for the first time.

Colour reversal films require critical exposure and the following recommendations should be regarded merely as a guide for typical films. Assessment of ideal colour balance is to some extent subjective and additional filtration may therefore be required to achieve fully satisfactory results. The severe colour casts given by some film types are very difficult to compensate and these films are therefore not recommended for long exposures.

Exposure increments and compensating filters for typical colour films

Exposure increments are quoted below in $\frac{1}{3}$ -stop intervals corresponding to one 'click' of the J35 speed dial.

Film type	Indicated shutter speed (sec)				
	1/10	1	10	100	300
Agfachrome 50L 50 ASA/3100 K	*	No change No filter	No change No filter	+2/3 stop CC 20 B	+2 stops CC 30 B
Kodak 2483† Photomicrography film 16 ASA/5500 K	No change No filter	+2/3 stop CC 10 Y	+1 stop CC 10 Y	+2 stops CC 10 Y	Not recommended
Kodak High Speed Ektachrome (tungsten) 125 ASA/3200 K	No change No filter	No change No filter	+1 stop No filter	Not recommended	

*Agfachrome 50L Professional film is designed for long exposures and gives neutral balance from 1–10 seconds shutter speed. Exposure below $\frac{1}{4}$ sec may give a bluish cast requiring a CC 10Y (or similar) filter. See leaflet t.01 'Agfachrome Professional Films.'

†These corrections assume that a 3200 K source is used with 80A conversion filter. Corrections will be somewhat different under other conditions as the high contrast of this film tends to emphasise colour shifts. See leaflet 'Kodak Photomicrography Colour Film 2483' or Eastman-Kodak booklet 'Photography Through the Microscope' for further information.

